

BANDO BANCOLLAN SYNCHRONOUS BELTS

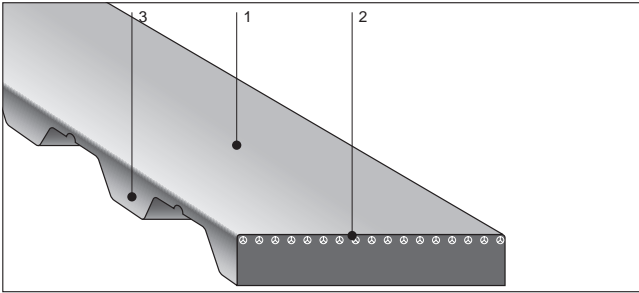

Construction

- 1: Polyurethane backing
- 2: Glass Fiber tensile members (For MXL, Aramid tensile members)
- 3: Polyurethane teeth

Features

- Non-slip
Accurate tooth dimensions and steel cord ensures minimal stretching, no slippage and constant speeds.
- High oil and ozone resistance.
- Special backside surfaces are available.
Bando can mold virtually any special configuration on the belt's backside surface.

Size Mark

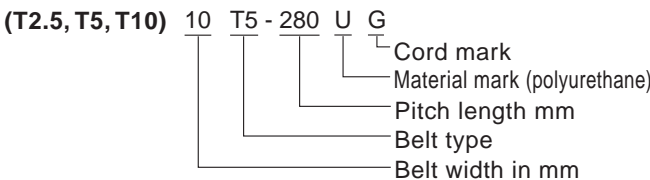
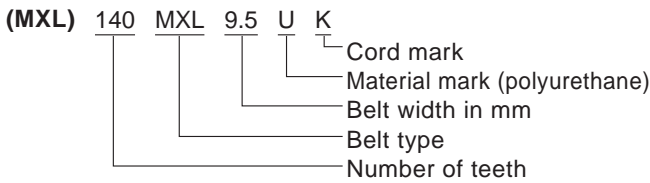

We recommend Bando Bancollan Synchronous Belts are ideal for the following conditions.

- For improved performance from the belt i.e. as a conveyor or print drive, special shapes or indications can be formed on the backside.
- High oil or ozone resistance.
- High shock load applications.

Dimensions

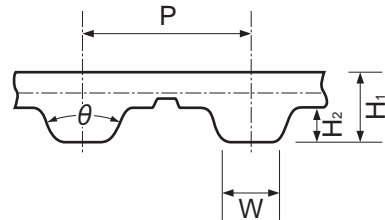

Type	P	W	H ₁	H ₂	θ
MXL	2.032mm (0.080")	0.76mm (0.030")	1.2mm (0.043")	0.51mm (0.020")	40°
XL	5.08mm (0.200")	1.35mm (0.053")	2.25mm (0.089")	1.25mm (0.049")	40°
L	9.525mm (0.375")	3.2mm (0.126")	3.5mm (0.138")	1.9mm (0.075")	40°
T2.5	2.5mm (0.098")	1.0mm (0.039")	1.3mm (0.051")	0.7mm (0.028")	40°
T5	5.0mm (0.197")	1.80mm (0.071")	2.2mm (0.087")	1.2mm (0.047")	40°
T10	10.0mm (0.394")	3.5mm (0.138")	4.5mm (0.177")	2.5mm (0.098")	40°

(XL, L)

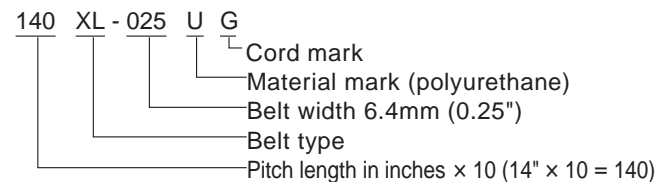

For XL type, Aramid cord (K) is available.

BANDO BANCOLLAN STS BELTS

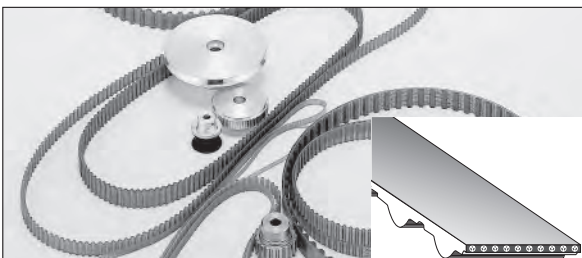

Size Mark

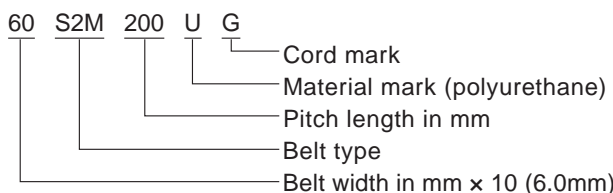

Dimensions

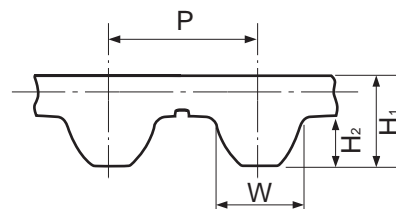

Type	P	W	H ₁	H ₂	Cord Mark
S2M	2.0mm	1.3mm	1.4mm	0.76mm	G K
S3M	3.0mm	1.95mm	2.0mm	1.14mm	G K

※Cord mark
G...Glass cord
K...Aramid cord

SYNCHRONOUS BELTS (POLYURETHANE)

BANDO BANCOLLAN SYNCHRONOUS / STS BELTS

Standard Sizes

BELT TYPE	P(mm)	NOMINAL WIDTH	BELT NUMBER (PITCH LENGTH mm)
S2M (Polyurethane)	2.0	40, 60, 100	76, 78, 80, 86, 90, 92, 100, 102, 106, 110, 112, 114, 116, 120, 122, 126, 128, 138, 140, 142, 144, 148, 158, 160, 164, 166, 168, 170, 172, 176, 180, 184, 186, 190, 200, 206, 214, 216, 218, 220, 224, 230, 234, 236, 238, 240, 250, 256, 258, 260, 264, 266, 280, 290, 296, 300, 314, 316, 320, 334, 340, 354, 360, 370, 380, 396, 400, 436, 440, 448, 454, 460, 474, 480, 488, 494, 500, 504, 520, 544, 548, 560, 580, 600, 620, 630, 654, 710, 754, 790, 800, 806, 828, *900, 976, *1000, *2250 *Aramid Cordonly
S3M (Polyurethane)	3.0	60, 100, 150	120, 144, 150, 159, 162, 171, 174, 177, 186, 192, 195, 201, 204, 210, 213, 219, 222, 225, 234, 237, 240, 246, 252, 255, 264, 267, 270, 276, 285, 300, 312, 318, 327, 339, 342, 354, 360, 378, 384, 390, 396, 402, 405, 417, 420, 432, 447, 453, 459, 486, 501, 504, 507, 513, 516, 519, 537, 564, 588, 600, 609, 633, 660, 666, 681, 699, 750, 765, 774, 789, 804, 810, 885, 900, 936, 951, 1005, 1050, 1146, 1260, 1383, 1596, 1800, 2100
BELT TYPE	P(mm)	NOMINAL WIDTH	BELT NUMBER (NO OF TEETH)
T2.5 (Polyurethane)	2.500	3, 5, 7, 10, 13	120, 145, 160, 177.5, 200, 230, 245, 265, 285, 305, 317.5, 330, 380, 420, 480, 492.5, 500, 600, 620, 650, 780, 915, 950
T5 (Polyurethane)	5.000	5, 10, 15, 20, 25	165, 185, 200, 215, 220, 225, 245, 250, 255, 260, 270, 275, 280, 295, 300, 305, 325, 330, 340, 350, 355, 365, 375, 390, 400, 410, 420, 425, 450, 455, 465, 475, 480, 500, 510, 525, 545, 550, 560, 575, 600, 610, 620, 630, 640, 650, 660, 675, 690, 695, 700, 720, 750, 780, 800, 815, 840, 850, 900, 940, 990, 1000, 1075, 1100, 1140, 1215, 1380, 1440
T10 (Polyurethane)	10.000	15, 20, 25, 30, 50	260, 370, 400, 410, 440, 450, 500, 530, 560, 610, 630, 660, 690, 700, 720, 750, 780, 810, 840, 880, 890, 900, 920, 960, 970, 980, 1000, 1010, 1080, 1110, 1140, 1150, 1210, 1240, 1250, 1300, 1320, 1350, 1390, 1400, 1420, 1440, 1450, 1460, 1500, 1560, 1610, 1750, 1780, 1880, 1960, 2250
MXL (Polyurethane)	2.032	3.2, 4.8, 6.4, 9.5, 12.7	30, 35, 37, 40, 41, 42, 45, 48, 50, 52, 53, 54, 55, 56, 57, 60, 63, 65, 67, 68, 70, 71, 72, 73, 75, 76, 79, 80, 81, 82, 83, 85, 87, 88, 90, 91, 94, 95, 97, 98, 100, 102, 103, 106, 110, 112, 114, 115, 118, 120, 123, 125, 126, 128, 130, 132, 134, 136, 140, 144, 150, 155, 157, 160, 165, 170, 175, 180, 184, 190, 194, 195, 200, 205, 210, 212, 215, 220, 225, 230, 236, 240, 250, 255, 260, 265, 270, 280, 295, 300, 305, 310, 330, 336, 340, 347, 350, 360, 438, 453, 468, 579, 660
BELT TYPE	P(mm)	NOMINAL WIDTH	BELT NUMBER (PITCH LENGTH INCHES×10)
XL (Polyurethane)	5.080	025, 031, 037, 050, 075	60, 70, 80, 84, 90, 96, 100, 110, 114, 120, 130, 140, 150, 154, 156, 160, 166, 168, 170, 176, 180, 190, 198, 200, 202, 210, 212, 220, 230, 236, 240, 250, 254, 260, 270, 290, 300, 320, 330, 376, 396, 414, 430, 460, 478, 480, 490, 512, 564, 630, 670, 686, 730
L (Polyurethane)	9.525	050, 075, 100, 150, 200	124, 150, 165, 187, 210, 225, 240, 255, 270, 285, 300, 322, 345, 360, 367, 390, 420, 450, 480, 510, 540, 600

Authorised distributor:



TYMA CZ, s.r.o.

Na Pískách 731, CZ- 400 04 Trmice

Phone: +420 475 655 010, Email: info@tyma.cz

www.tyma.cz

BANDO BANCOLLAN DOUBLE SIDED SYNCHRONOUS / STS BELTS

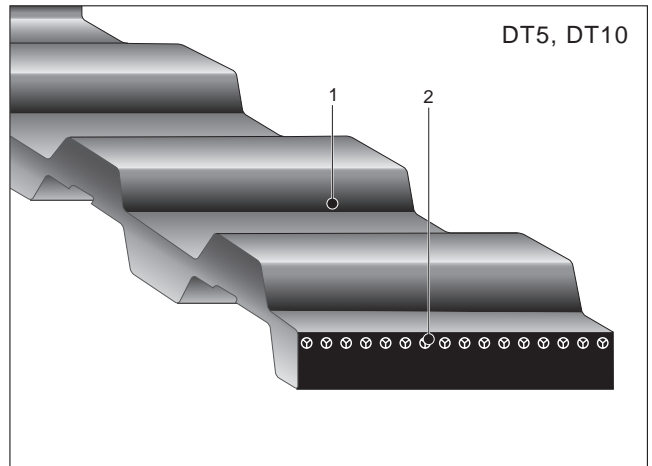
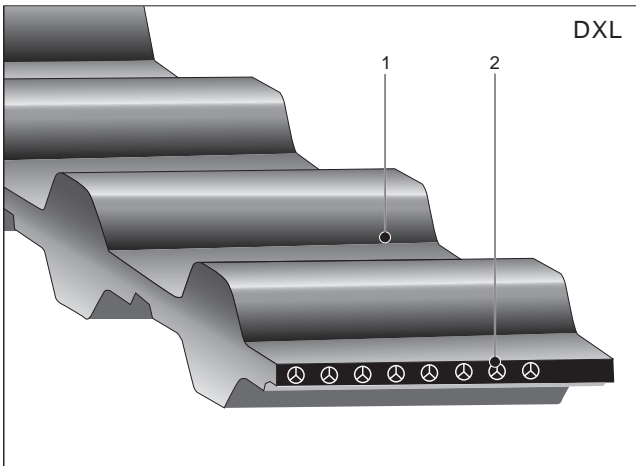

Construction

- 1: Polyurethane teeth
- 2: DXL = Aramid
DT5, DT10 = Glass Fiber

Dimension and Size Mark

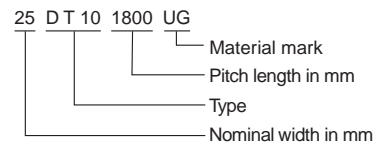
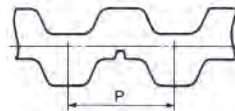
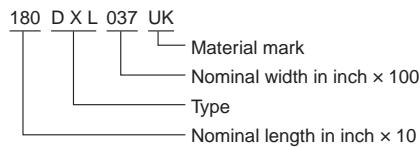
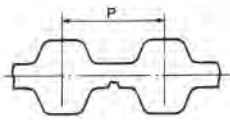

※UK = Aramid UG = Glass Fiber

Standard Sizes

Type	P(mm)	Nominal Width	Nominal Length
DXL	5.080	025, 031, 037, 050, 075	140, 146, 150, 166, 170, 180, 190, 200, 210, 220, 230, 240, 270, 290, 300, 320, 376, 400, 430, 490

Type	P(mm)	Nominal Width	Nominal Length
DT5	5.00	5, 10, 15, 20, 25	300, 410, 460, 480, 515, 550, 590, 620, 650, 700, 750, 800, 815, 860, 900, 940, 1075, 1100
DT10	10.00	15, 20, 25, 30, 50	260, 530, 630, 660, 700, 720, 800, 840, 900, 980, 1100, 1210, 1240, 1250, 1320, 1350, 1420, 1500, 1610, 1800, 1880

Authorised distributor:



TYMA CZ, s.r.o.
 Na Pískách 731, CZ- 400 04 Trmice
 Phone: +420 475 655 010, Email: info@tyma.cz
www.tyma.cz

SYNCHRONOUS BELTS (POLYURETHANE)

BANDO BANCOLLAN SYNCHRONOUS BELTS TN-TYPE

Bancollan Synchronous belts TN type is a highly precise, extra light-duty belt with a unique profile.

Features + Benefits

- Complete synchronized transmission
- Light drive system
- Calm and smooth drive

Dimensions

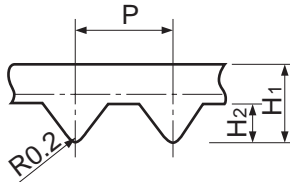

Type	P	H ₁	H ₂
TN15	1.5	1.3	0.7
TN10	1.0	0.85	0.44

unit: mm

Size Mark

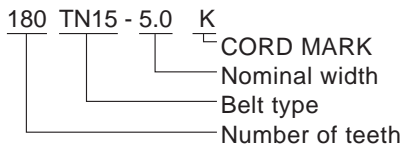

※CORD MARK

K=Aramid
T=Polyester

(As for TN10, polyester cord is only available)

Standard Width

TN15

Nominal Width	Width (mm)
3.0	3.0
5.0	5.0
7.0	7.0
10.0	10.0
13.0	13.0

TN10

Nominal Width	Width (mm)
1.0	1.0
2.0	2.0
3.0	3.0

Standard Sizes

TN15 Type

BELT NUMBER	Pitch length (mm)	Number of teeth	BELT NUMBER	Pitch length (mm)	Number of teeth
43TN15	64.5	43	270TN15	405.0	270
50TN15	75.0	50	271TN15	406.5	271
60TN15	90.0	60	290TN15	435.0	290
63TN15	94.5	63	298TN15	447.0	298
79TN15	118.5	79	300TN15	450.0	300
82TN15	123.0	82	310TN15	465.0	310
100TN15	150.0	100	320TN15	480.0	320
110TN15	165.0	110	330TN15	495.0	330
114TN15	171.0	114	334TN15	501.0	334
120TN15	180.0	120			
130TN15	195.0	130	339TN15	508.5	339
131TN15	196.5	131	340TN15	510.0	340
140TN15	210.0	140	350TN15	525.0	350
			360TN15	540.0	360
			370TN15	555.0	370
150TN15	225.0	150	380TN15	570.0	380
160TN15	240.0	160	390TN15	585.0	390
170TN15	255.0	170	400TN15	600.0	400
180TN15	270.0	180	421TN15	631.5	421
			441TN15	661.5	441
186TN15	279.0	186	460TN15	690.0	460
190TN15	285.0	190	480TN15	720.0	480
192TN15	288.0	192	481TN15	721.5	481
196TN15	294.0	196			
200TN15	300.0	200			
220TN15	330.0	220			
230TN15	345.0	230			
240TN15	360.0	240			
250TN15	375.0	250			
260TN15	390.0	260			

TN10 Type

BELT NUMBER	Pitch length (mm)	Number of teeth
50TN10	50.0	50
60TN10	60.0	60
80TN10	80.0	80
81TN10	81.0	81
90TN10	90.0	90
98TN10	98.0	98
100TN10	100.0	100
107TN10	107.0	107
110TN10	110.0	110
120TN10	120.0	120
130TN10	130.0	130
140TN10	140.0	140
150TN10	150.0	150
160TN10	160.0	160
170TN10	170.0	170
200TN10	200.0	200
250TN10	250.0	250
287TN10	287.0	287
310TN10	310.0	310

Authorised distributor:



TYMA CZ, s.r.o.

Na Pískách 731, CZ- 400 04 Trmice
Phone: +420 475 655 010, Email: info@tyma.cz
www.tyma.cz